

ISOMETRIC  
NTS

REF No	DESCRIPTION
1	
2	
3	
4	
5	
6	
7	
8	
9	
10	

REV	BY	DATE	DESCRIPTION	CKD	APP	ENG

DRAWN	L.CARRINGTON	17/09/2022
CHECKED	T.RAYDEN	17/09/2022
APPROVED	L.CARRINGTON	17/09/2022
ENG. APPROVED	-	-

LPSC DESIGNS  
SIM RACING RIG  
COCKPIT  
MANUFACTURING DETAILS

SCALE: 1:7	SHEET 1 OF 4
DRAWING NUMBER COCKPIT-01	REV 0
PROJECT NUMBER: 1000000	

# PVC FITTINGS

ITEM NO.	QTY	DESCRIPTION	MASS (kg ea)
1	4	45° ELBOW - 2"	0.2
2	9	90° ELBOW - 2"	0.2
3	12	90° TEE - 2"	0.3
TOTAL MASS :			6.2 kg

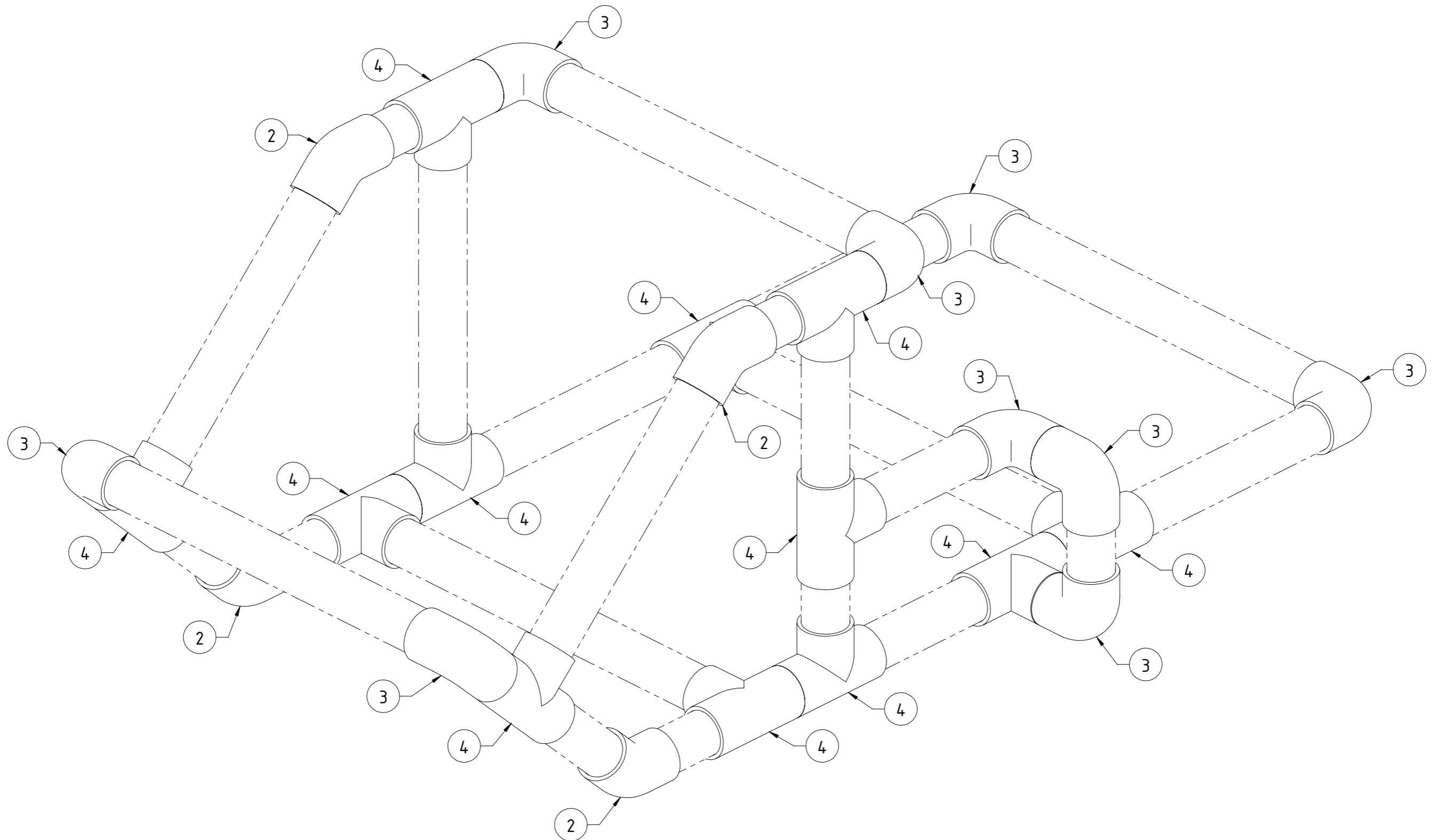

ISOMETRIC  
NTS

REF No	DESCRIPTION
1	2

REV	BY	DATE	DESCRIPTION	CKD	APP	ENG

DRAWN	L.CARRINGTON	17/09/2022
CHECKED	T.RAYDEN	17/09/2022
APPROVED	L.CARRINGTON	17/09/2022
ENG. APPROVED	-	-

LPSC DESIGNS  
SIM RACING RIG  
COCKPIT  
MANUFACTURING DETAILS

SCALE: 1:5	SHEET 2 OF 4
DRAWING NUMBER COCKPIT-01	REV 0
PROJECT NUMBER: 1000000	⊕ ↻

# PVC PIPE

ITEM NO.	QTY.	DESCRIPTION	MASS (kg ea)
1	5	2" PIPE x 606 LG	0.7
2	2	2" PIPE x 446 LG	0.5
3	1	2" PIPE x 468 LG	0.5
4	1	2" PIPE x 401 LG	0.4
5	2	2" PIPE x 391 LG	0.4
6	3	2" PIPE x 258 LG	0.3
7	2	2" PIPE x 207 LG	0.2
8	2	2" PIPE x 156 LG	0.2
9	2	2" PIPE x 143 LG	0.2
10	2	2" PIPE x 122 LG	0.1
11	9	2" PIPE x 76 LG	0.1

TOTAL MASS : 9.4 kg  
 TOTAL LENGTH OF PIPE REQ'D : 8.1 m

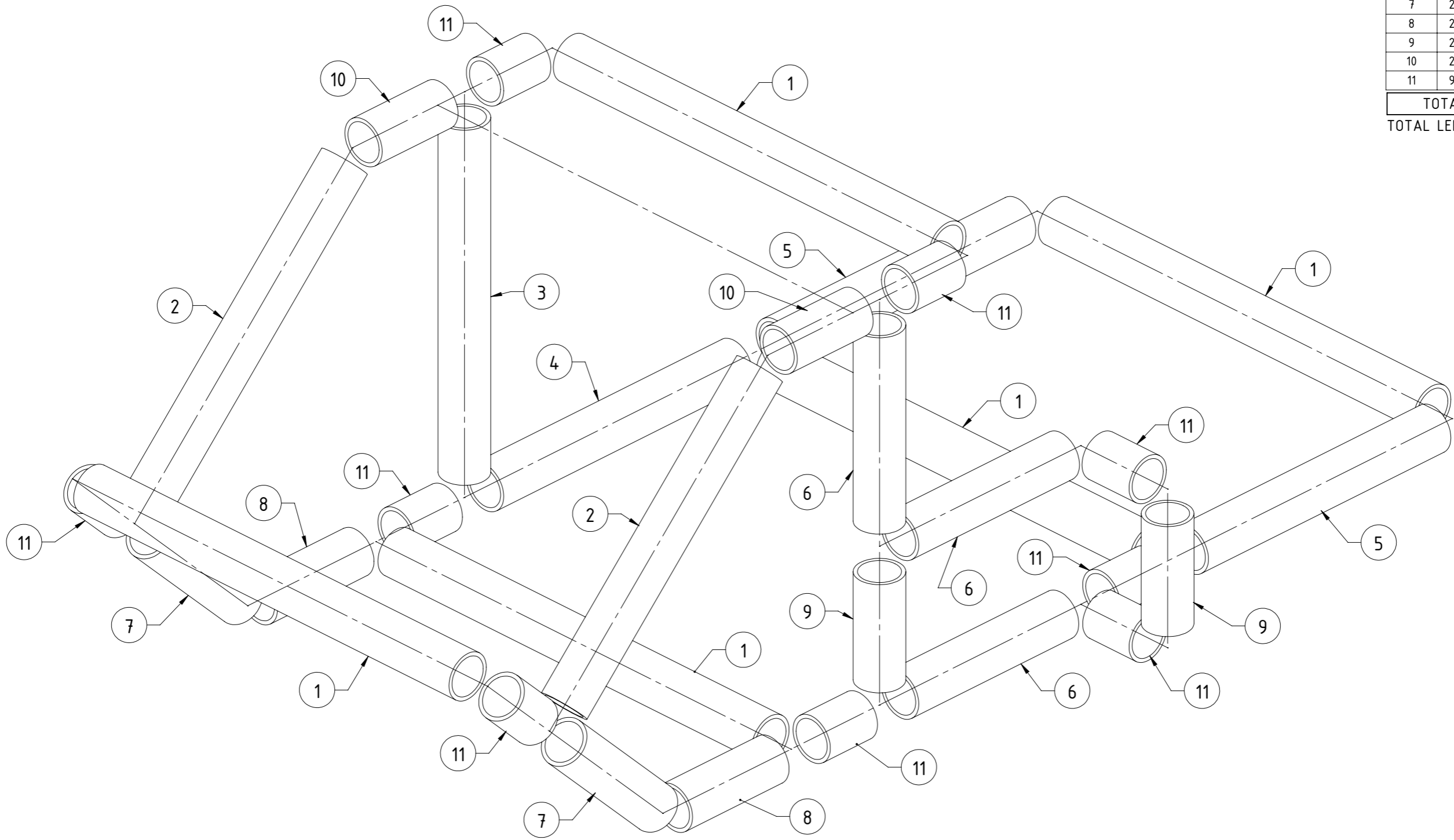

ISOMETRIC  
NTS

REF No	DESCRIPTION	REV	BY	DATE	DESCRIPTION	CKD	APP	ENG
1								

DRAWN	L.CARRINGTON	17/09/2022
CHECKED	T.RAYDEN	17/09/2022
APPROVED	L.CARRINGTON	17/09/2022
ENG. APPROVED	-	-

LPSC DESIGNS  
 SIM RACING RIG  
 COCKPIT  
 MANUFACTURING DETAILS

SCALE: 1:5	SHEET 3 OF 4
DRAWING NUMBER COCKPIT-01	REV 0
PROJECT NUMBER: 1000000	

TOTAL MASS : 15.8 kg

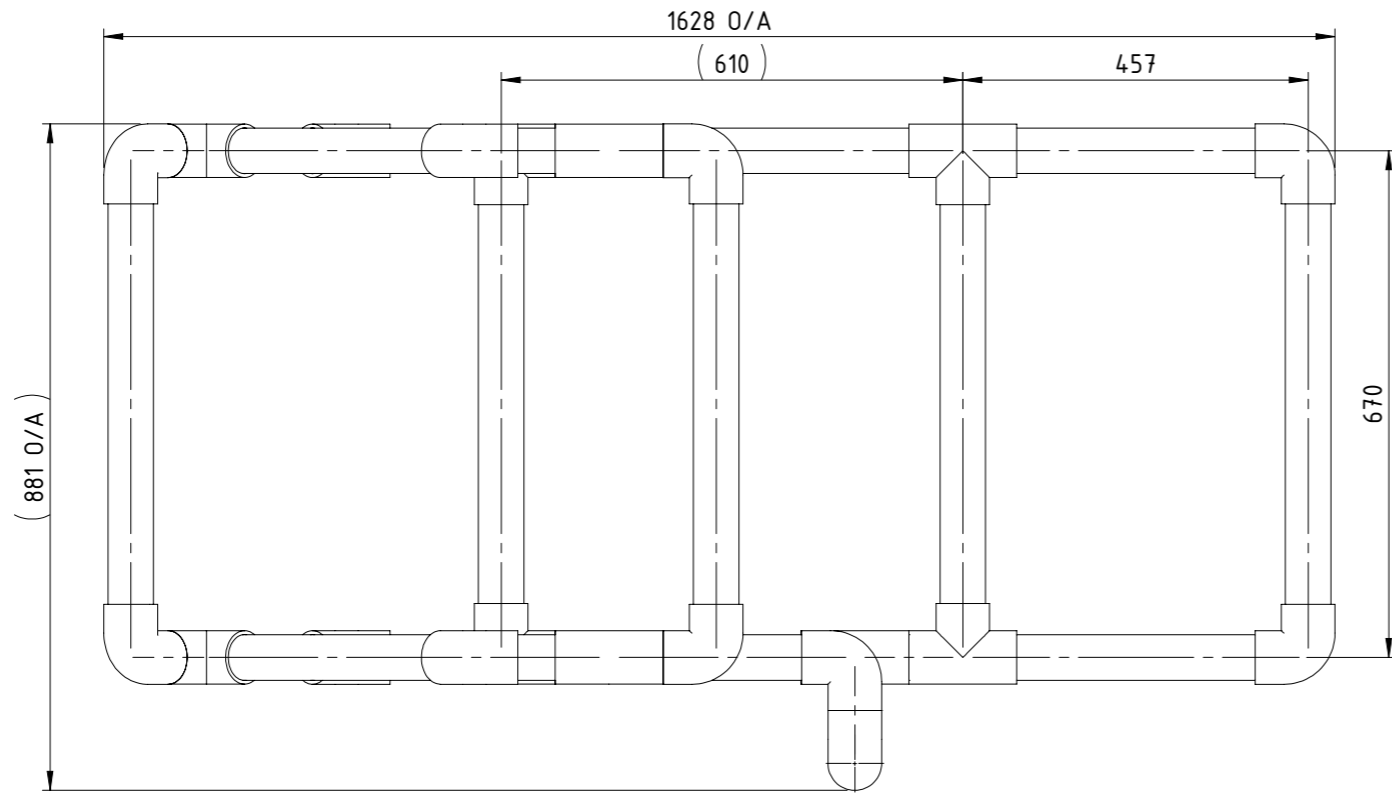

PLAN

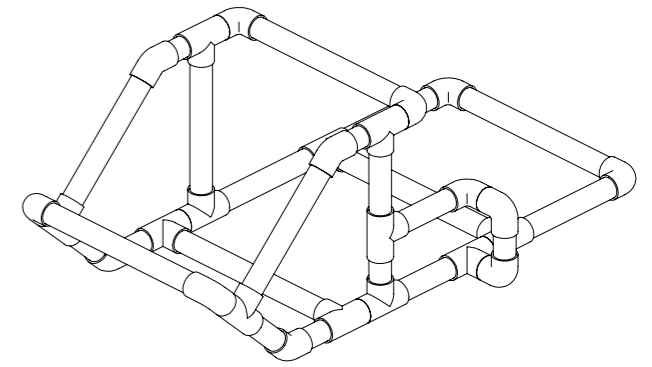

ISOMETRIC  
NTS

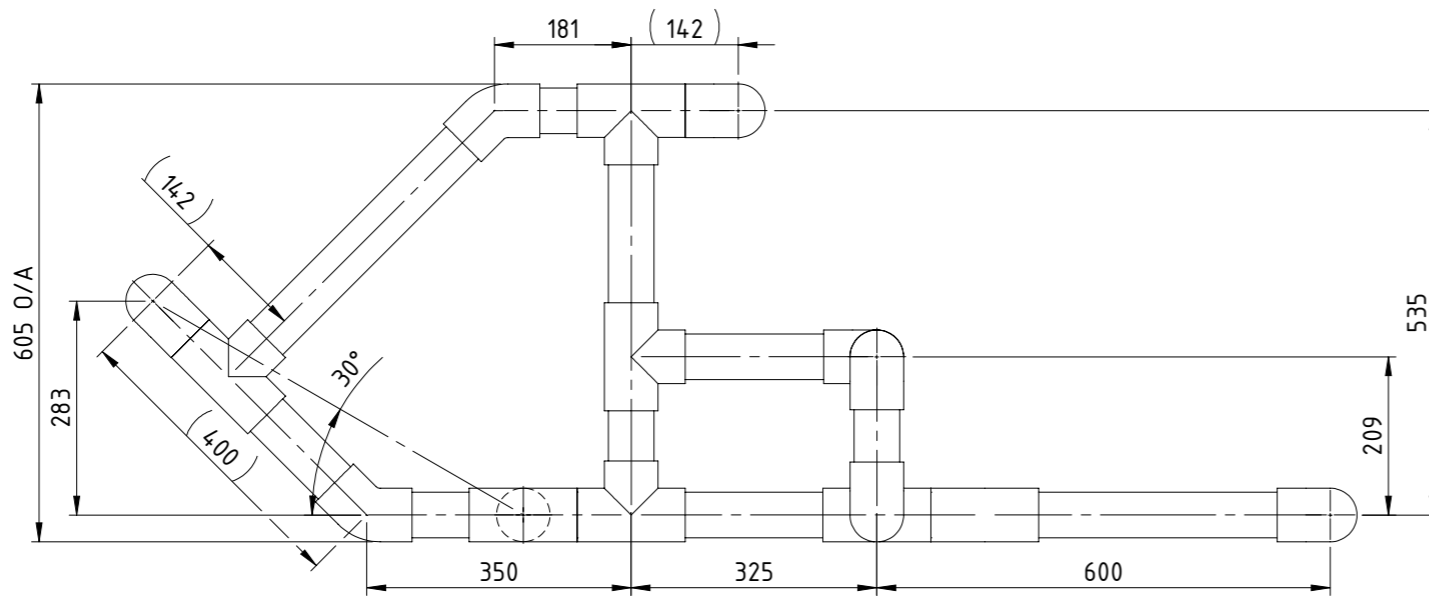

ELEVATION

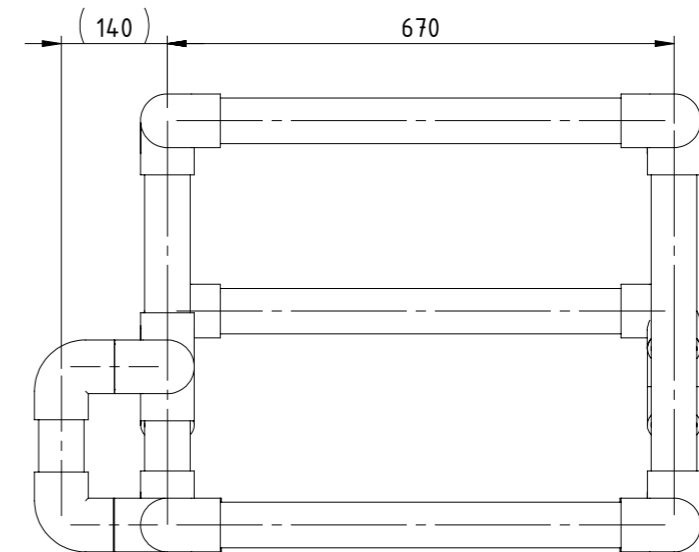

SIDE ELEVATION

REF No	DESCRIPTION
1	2

REV	BY	DATE	DESCRIPTION	CKD	APP	ENG

DRAWN	L.CARRINGTON	17/09/2022
CHECKED	T.RAYDEN	17/09/2022
APPROVED	L.CARRINGTON	17/09/2022
ENG. APPROVED	-	-

LPSC DESIGNS  
SIM RACING RIG  
COCKPIT  
MANUFACTURING DETAILS

SCALE: 1:10	SHEET 4 OF 4
DRAWING NUMBER COCKPIT-01	REV 0
PROJECT NUMBER: 1000000	⊕ ↙